

---

## Validation and Updating of FE Models for Structural Analysis Training Administrative Information ( Feb 8-10, 2023 )

**Background Discussion & Abstract:** Navcon Engineering has been presenting modal testing seminars since 1990. During the “*Hands-On Modal Testing & Analysis Course*” we discuss modal theory and analysis, but really focus on the practical aspects of modal testing including test planning, data acquisition, data reduction, parameter estimation and results presentation. Over the past few years, many FE Analysts have attended our modal trainings. In addition, many more test engineers tell us that they are being tasked with Pretest Analysis and Model Correlation. We have had numerous requests to put together seminar tying the test with the analysis.

During the **Validation and Updating of FE Models for Structural Analysis Seminar**, the participants will not only learn the basic principles of test-analysis correlation and finite element model updating, but will also get hands-on experience using specialized software (**FEMtools**). All aspects of a FE model validation process will be reviewed including the import and correlation of FEA and test models, the correlation of FEA/test data and results, the selection of model updating parameters, the definition of realistic correlation targets, the computation of sensitivity coefficients, running of updating loops and post processing of results. Complementary technologies and applications such as probabilistic analysis, pretest planning, structural modifications, force identification and material characterization will also be discussed and applied.

Attendees are encouraged to bring a laptop computer with them for use during the laboratory exercises. We will load a fully functional copy of **FEMtools** on the laptops which will operate for 30 days. The software can be used to repeat the laboratory exercises after the class or for the analysis of the attendees' FEA/test data.

**Intended Audience:** This intensive three day training is intended for engineers tasked with CAE, structural dynamics analysis, modal testing, quality assurance, and noise and vibration troubleshooting. The methods shown can be applied to a wide range of industrial applications.

**Course Objective:** By the end of the course, attendees will gain an understanding of the principles of FE model validation and updating and how they can be applied in practice.

**Presenters:** The course will be presented by experienced engineers who have consulted, developed software and presented courses for companies worldwide in the field of modal testing, vibration control, structural dynamics, and finite element model updating.

**Registration:** Advanced registration is required. You can register online or complete and return the enclosed registration form. The registration form can be downloaded from the Navcon web site (<http://www.navcon.com/AdvancedModal.htm>). The number of participants is limited and early registration is recommended.

**Course Fee:** \$2,600 per attendee. The course fee includes participation, course notes, lunches and refreshments. A full refund will be made for all cancellations received 30 days before the start of the course. No refunds will be granted after the 30-day deadline. Substitute attendees will be accepted at any time. In the event that we have to cancel the course, the course fee will be refunded in full, but we disclaim any further liability.

---

## Validation and Updating of FE Models for Structural Analysis Training Course Outline

### Day 1 : 8:30 am – 5:30 pm

#### Introduction

- Needs, motivation and strategies for model validation
- Discussion of processes and data flow
- Managing model validation projects

#### Database Management and Finite Element Analysis

- Importing standard FEA and test data (model, shapes, FRF)
- Using finite element analysis solvers (mass analysis, static analysis, modes analysis, FRF synthesis, forced response analysis) and piloting standard FEA software.
- Examining the analytical and experimental database. Checking database integrity.
- Database operations: coordinate system transformations, defining sets, mode shape normalization,...

#### Correlation Analysis

- Mapping FE and test models (geometry correlation)
- Expansion and truncation of mode shapes
- Global and local shape correlation
- Reduction of system matrices (Guyan, IRS, Craig-Bampton)
- Mode shape orthogonality checking
- FRF correlation

#### Pretest Analysis

- Overview of pretest analysis procedures
- Selection of target modes
- Selection of sensor locations; manual and automated procedures
- Creation of test models

### Day 2 : 8:30 am – 5:30 pm

#### Sensitivity Analysis and Model Updating

- Selection of parameters and responses
- Sensitivity analysis

- Using mass information in model updating
- Model updating using static test data
- Modal-based model updating
- FRF-based model updating
- Parameter relations
- Multi-model updating
- Superelement-based model updating
- Model updating using DOE/RSM

#### Probabilistic Model Validation and Updating

- Overview and theoretical background
- Data preparation and postprocessing
- Probabilistic model updating methods

### Day 3 : 8:30 am – 5:30 pm

#### Applications of Model Updating

- Material identification
- Equivalent property identification
- Structural damage identification

#### Structural Dynamics Modification

- Overview and theoretical backgrounds
- Definition of modification elements
- Parameter slider and range controls
- Applications of SDM in model updating

#### Force Identification and Updating

- Overview and theoretical background
- Data preparation
- Nodal and pressure load identification

#### Script Development

- Database management
- Analysis integration and process automation
- Mesh manipulation (refinement, coarsening, element type conversion, transformation,...)

#### Review and Closure

- Review and summary
- Ongoing research & development
- Q&A

**SEMINAR LABORATORIES:** Attendees conduct a number of “real-world” Hands-On laboratories demonstrating **Modal Pretest Analysis** (target mode selection, test article mounting, optimal sensor placement, optimal excitation locations, transducer mass loading, generation of the test model), **FEM-Test Model Correlation** (MAC & Orthogonality), **Finite Element Model Updating** (sensitivity analysis, FRF & ODS based, bottom-up, automated, optimization) and more.

**FEM-Test Correlation (Point & Mode Pairs)**

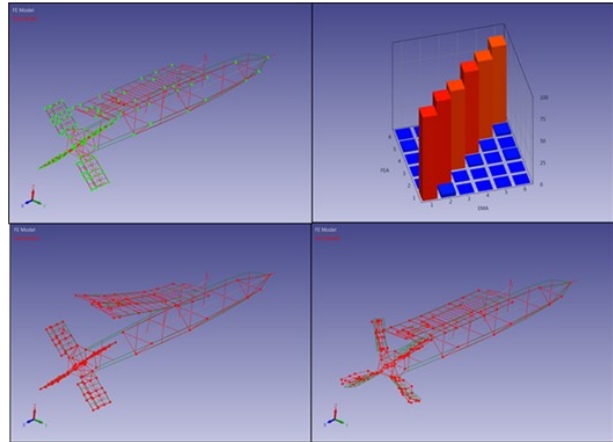

**Pretest (Normalized Model Displacement)**

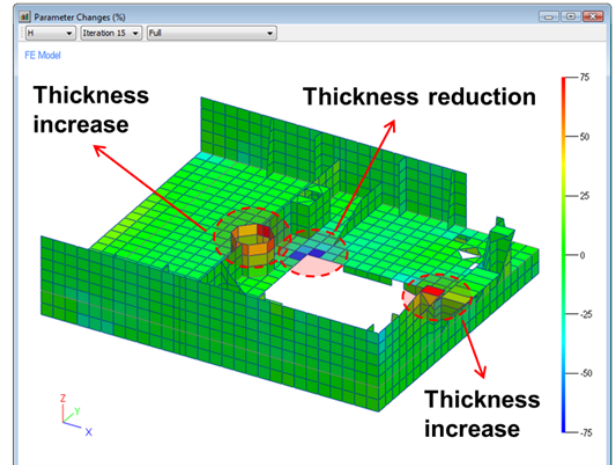
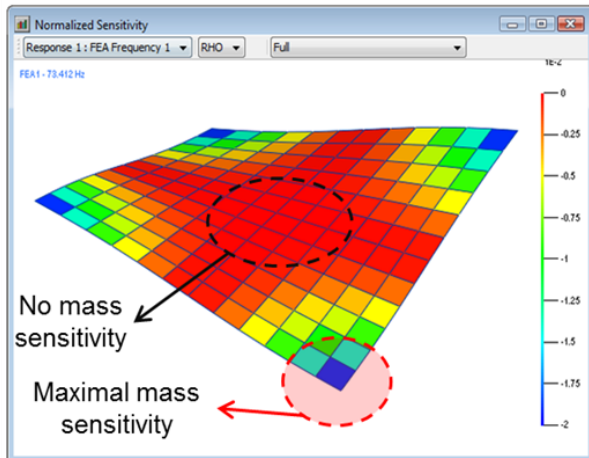
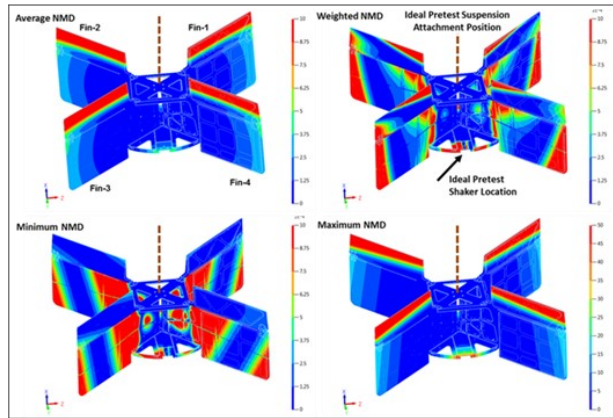
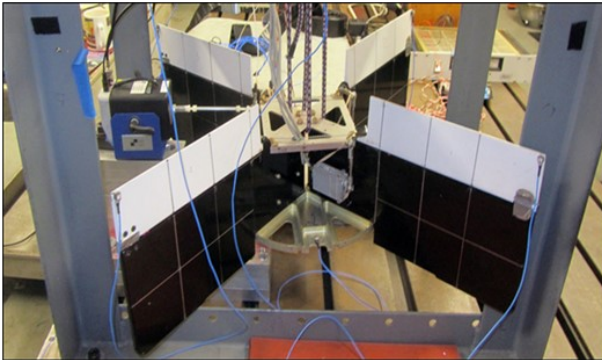

## Validation and Updating of FE Models for Structural Analysis Training Registration Form

<b>Seminar</b>	Feb 8-10, 2023 <input type="checkbox"/>
<b>Name(s)</b>	.....
<b>Company</b>	.....
<b>Address</b>	.....
<b>City, State, Zip</b>	.....
<b>E-Mail</b>	.....
<b>Phone</b>	<b>Fax</b> .....
<b>Date</b>	<b>Signature</b> .....
<b>Payment</b>	<b>P.O. No.</b> ..... <b>Company Check</b> <input type="checkbox"/> <b>Payment: US \$ <u>2,600.00</u></b> <b>Bank Transfer</b> <input type="checkbox"/> <b>Credit Card: Visa</b> <input type="checkbox"/> <b>MasterCard</b> <input type="checkbox"/> Credit Card #: _____ Expiration Date: ____ / ____ Name on Credit Card: _____ Billing Address: _____ Billing Zip Code: _____ Card Verification Value CVV #: _____ (3 digits on the back)

*The course fee is \$2,600 per attendee. We accept company purchase orders with terms of Net 30 days, company checks, money orders, bank transfers and credit card (Visa, MasterCard). A full refund will be made for all cancellations received 30 days before the start of the course. If we must cancel the course, the registration fee will be refunded in full, but we disclaim any further liability. The course fee includes participation, course notes, lunches and refreshments. We offer vegetarian options and we will try to accommodate other dietary requests; please let us know in advance. The training room has stairway access only (no elevator or escalator access). For administrative & technical questions please call 714-441-3488. To register, please fax this page to +1-714-441-3487 or email to [webinfo@navcon.com](mailto:webinfo@navcon.com).*